

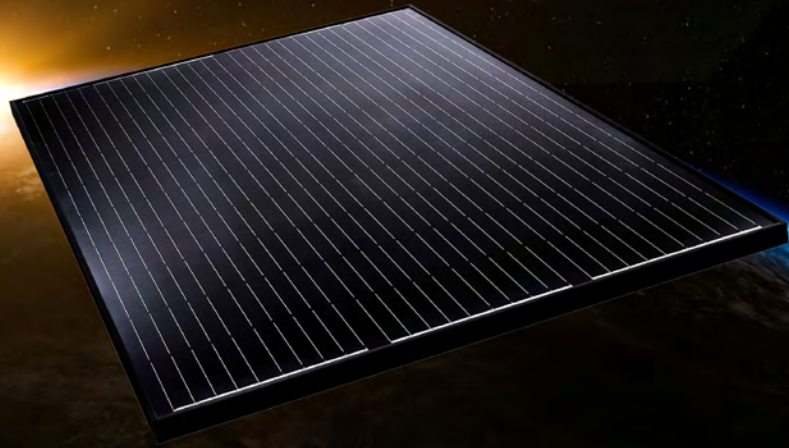

**FULL
SQUARE**



FU 315 / 320 / 325 / 330 M NEXT - All Black
Monocrystalline Photovoltaic Module - 60 cells

Engineered
in Italy



GENERAL FEATURES

- **Total black look for particular architectural requirements**
- **20-year product warranty**
- **Bigger high-efficiency PERC cells** optimized for low irradiance decrease ohmic losses and increase the yield
- **Tempered 3.2 mm glass** for optimal mechanical stability and transparency
- Maximum **resistance against hail** (83 km/h, 2.5 mm)
- Quality control with **electroluminescence (EL) tests** on each module

CERTIFICATIONS

- > **IEC 61215:2016 - IEC 61730:2016 & Factory Inspection**
- > **Fire Resistance - Class C**
- > **Salt Corrosion Resistance** IEC 61701
- > **Ammonia Corrosion** IEC 62716
- > **Dust and Sand Resistance** IEC 60068-2-68
- > **PID Certified** 2 PFG 2387



NEW

GUARANTEES

Performance guarantee

Max power decrease **0.5%/year**
97% at the end of first year
90% at the end of 20th year
87% at the end of **25th year**

Product guarantee

20 YEARS

Market standard performances
FuturaSun performances

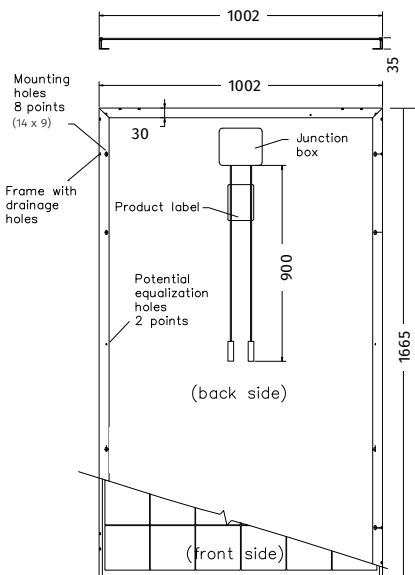
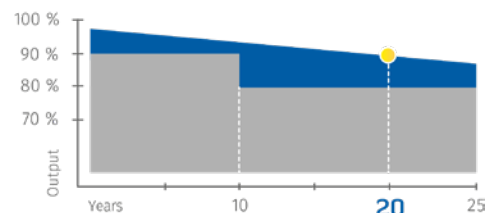

Note: dimensions in mm
tolerance +/- 2 mm

NEW

NEW

ELECTRICAL DATA

MODULE NEXT		FU 315 M	FU 320 M	FU 325 M	FU 330 M
<i>Standard Test Conditions STC: 1000 W/m² - AM 1.5 - 25 °C - tolerance: Pmax (±3%), Voc (±4%), Isc (±5%)</i>					
Module power (Pmax)	W	315	320	325	330
Open circuit voltage (Voc)	V	41.02	41.24	41.44	41.66
Short circuit current (Isc)	A	9.80	9.88	9.96	10.04
Maximum power voltage (Vmpp)	V	33.42	33.68	33.93	34.17
Maximum power current (Impp)	A	9.43	9.51	9.58	9.66
Module efficiency	%	18.81	19.18	19.48	19.78

<i>Nominal Module Operating Temperature NMOT: 800 W/m² - T=45 °C - AM 1.5</i>					
Module power (Pmax)	W	231.33	235.11	238.60	242.29
Open circuit voltage (Voc)	V	37.83	38.04	38.22	38.43
Short circuit current (Isc)	A	8.06	8.12	8.19	8.26
Maximum power voltage (Vmpp)	V	30.25	30.48	30.71	30.92
Maximum power current (Impp)	A	7.65	7.71	7.77	7.84

TEMPERATURE RATINGS

Temperature coefficient Isc	%/°C	0.037
Temperature coefficient Voc	%/°C	-0.266
Temperature coefficient Pmax	%/°C	-0.366
NMOT *	°C	45
Operating temperature	°C	from -40 to +85

* Nominal Module Operating Temperature

MECHANICAL SPECIFICATIONS

Dimensions	1665 x 1002 x 35 mm
Weight	18.4 kg
Glass	Tempered, ARC, Transparent, 3.2 mm
Cell encapsulation	EVA (Ethylene Vinyl Acetate)
Cells	60 monocrystalline PERC cells 158.75x158.75 mm
Backsheet	Composite multilayer film
Frame	Anodized black frame with mounting and drainage holes
Junction box	Certified according to IEC 62790, IP 68 approved, 3 bypass diodes
Cables	Solar cable, length 900 mm assembled with MC4-combinable plugs
Maximum reverse current (Ir)	20 A
Maximum system voltage	1000 V (1500 V on request)
Mechanical load (snow)	Design load: 3600 Pa 5400 Pa (including safety factor 1.5)
Mechanical load (wind)	Design load: 3600 Pa 5400 Pa (including safety factor 1.5)
Protection Class	II - accordance to IEC 61730
Packaging	Pallet: 30 pcs. / Container: 910 pcs.

Authorized Dealer



FuturaSun srl

Riva del Pasubio, 14 - 35013 Cittadella - Italy
Tel + 39 049 5979802 Fax + 39 049 0963081
www.futurasun.com - info@futurasun.it

2020_60m_315-330_next_ab_en